

INSTALLATION

1. INSTALL CAMSHAFT TIMING SPROCKET AND VVT TIMING SPROCKET

- (a) Align the camshaft knock pin with the knock pin groove on the sprocket side with the timing mark, and slide on the camshaft timing sprocket and VVT timing sprocket.

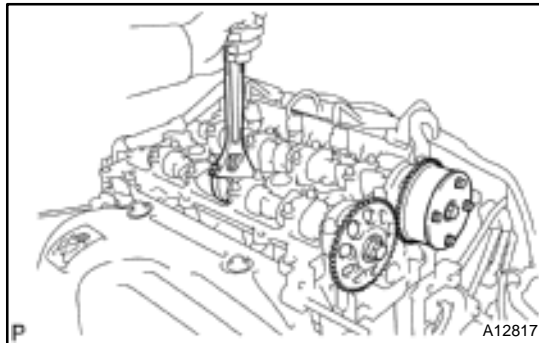

- (b) Temporary install the 2 timing sprocket bolts.
 (c) Hold the hexagon wrench head portion of the camshaft with a wrench, and tighten the timing sprocket bolt.

Torque: 54 N·m (551 kgf·cm, 40 ft·lbf)

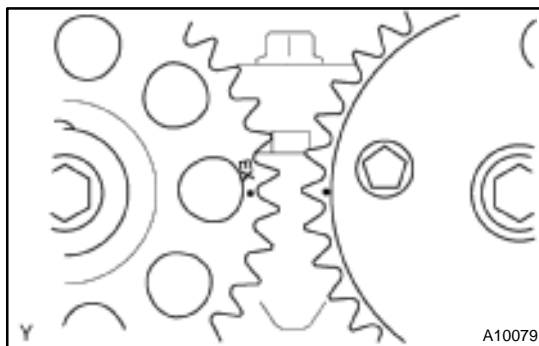

2. SET NO. 1 CYLINDER TO TDC/COMPRESSION

- (a) Turn the hexagonal wrench head portion of the camshafts, and align the point marks of the camshaft timing sprockets.

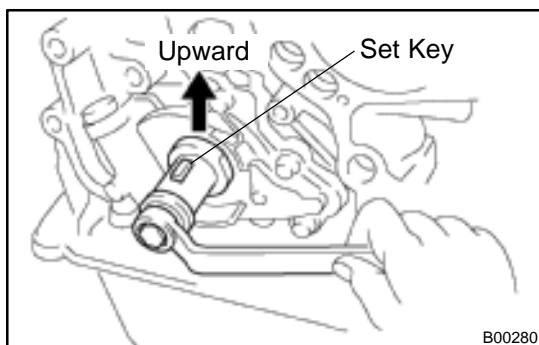

- (b) Using the crankshaft pulley bolt, turn the crankshaft and set the set key on the crankshaft upward.

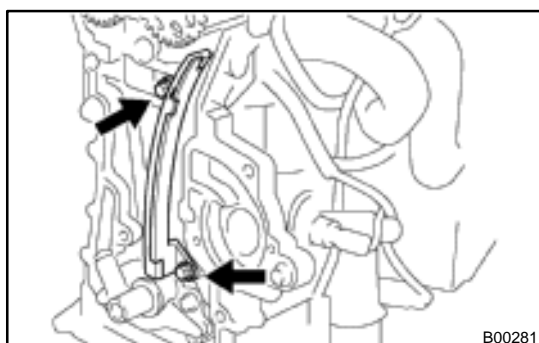

3. INSTALL CHAIN VIBRATION DAMPER

Install the damper with the 2 bolts.

Torque: 9 N·m (92 kgf·cm, 80 in.-lbf)

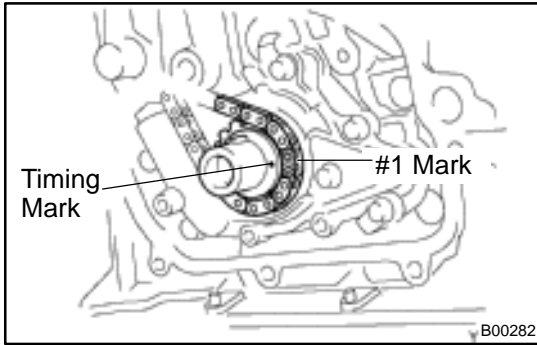

4. INSTALL TIMING CHAIN AND CRANKSHAFT TIMING SPROCKET

- (a) Install the timing chain on the crankshaft timing sprocket with the #1 mark link aligned with the timing mark on the crankshaft timing sprocket.

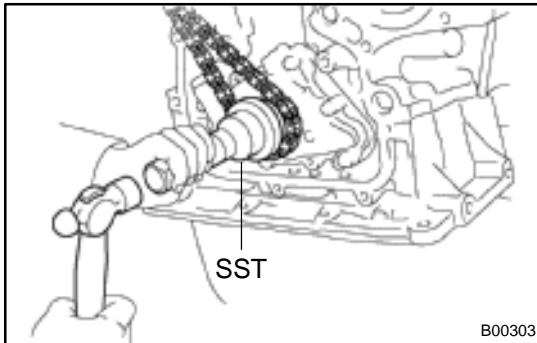

HINT:

If necessary, tap in the sprocket with SST and a hammer.

SST 09223-22010

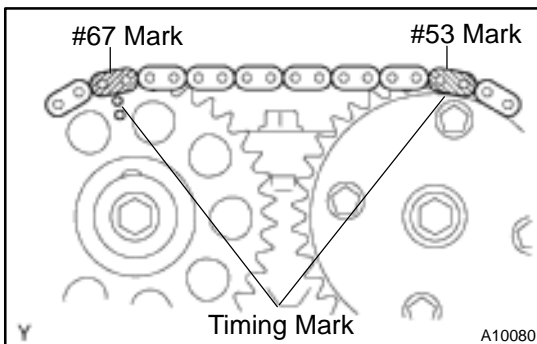

- (b) Install the timing chain on the camshaft timing sprocket and VVT timing sprocket with the #53 and #67 mark links aligned with the timing marks on the camshaft timing sprocket and VVT timing sprocket.

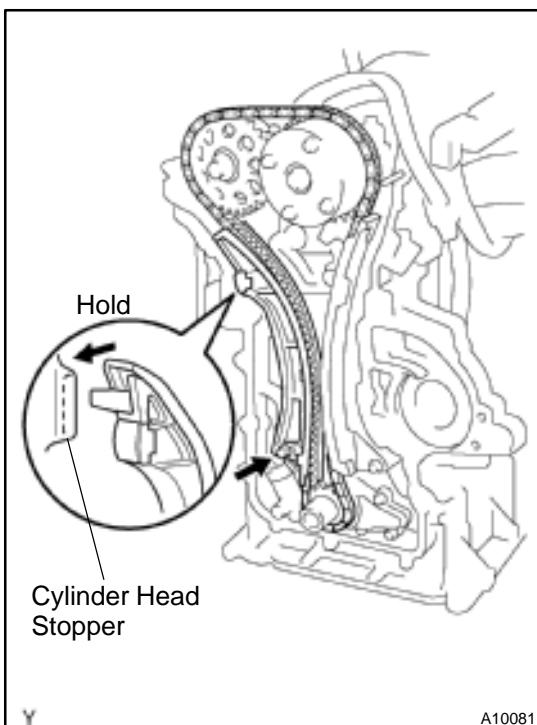

- (c) Check that the tension between the VVT timing sprocket and crankshaft timing sprocket.

5. INSTALL CHAIN TENSIONER SLIPPER

- (a) Install the slipper with the bolt.
Torque: 18.5 N·m (189 kgf·cm, 14 ft·lbf)
- (b) Check that the slipper is held on the cylinder head stopper.

NOTICE:

Do not turn the crankshaft.

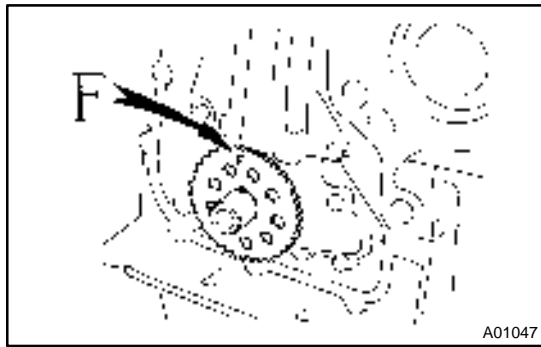

6. INSTALL CRANK ANGLE SENSOR PLATE

Install the plate with the F mark facing forward.

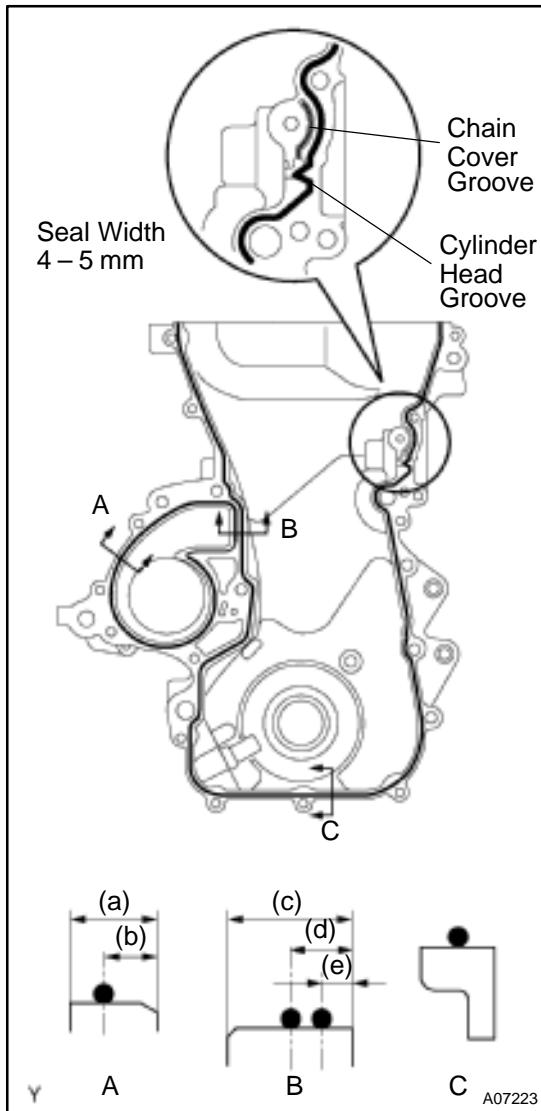

7. INSTALL TIMING CHAIN COVER AND WATER PUMP

(a) Remove any old packing (FIPG) material and be careful not to drop any oil on the contact surfaces of the timing chain cover, cylinder head and cylinder block.

- Using a razor blade and a gasket scraper, remove all the old packing (FIPG) material from the gasket surfaces and sealing grooves.
- Thoroughly clean all components to remove all the loose material.
- Using a non-residue solvent, clean both sealing surfaces.

(b) Apply seal packing to the timing chain cover as shown in the illustration.

Seal packing position:

(a) of A position	7 mm (0.28 in.)
(b) of A position	4.5 mm (0.177 in.)
(c) of B position	12 mm (0.47 in.)
(d) of B position	6 mm (0.24 in.)
(e) of B position	3 mm (0.12 in.)

Seal packing: Part No. 08826-00100 or equivalent

- Install a nozzle that has been cut to a 4 – 5 mm (0.16 – 0.20 in.) opening.

HINT:

Avoid applying an excessive amount to the surface.

- Parts must be assembled within 3 minutes of application. Otherwise the material must be removed and reapplied.
- Immediately remove nozzle from the tube and reinstall cap.

(c) Apply seal packing to 2 locations as shown in the illustration.

Seal packing: Part No. 08826-00080 or equivalent

- Install a nozzle that has been cut to a 4 – 5 mm (0.16 – 0.20 in.) opening.

HINT:

Avoid applying an excessive amount to the surface.

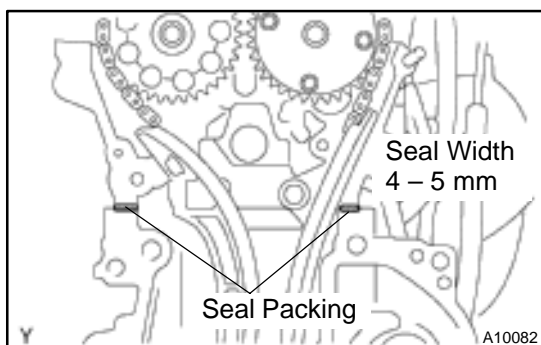

- Parts must be assembled within 3 minutes of application. Otherwise the material must be removed and reapplied.
- Immediately remove nozzle from the tube and reinstall cap.

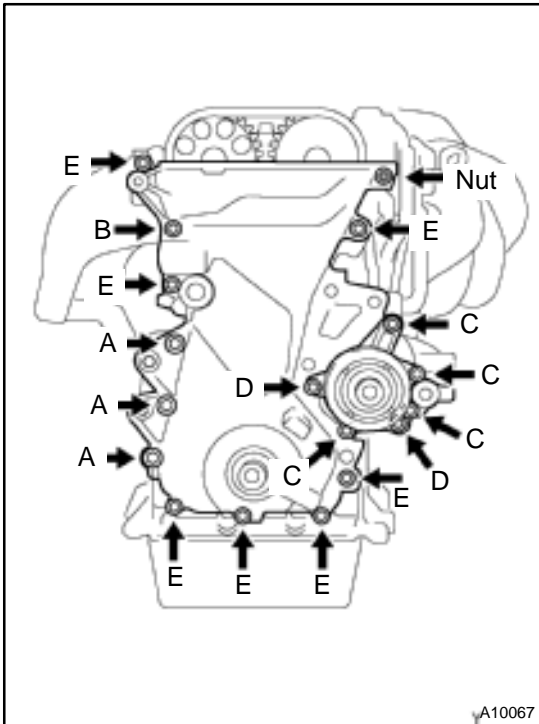

- (d) Install the timing chain cover, a new O-ring and the water pump with the 17 bolts and nut. Uniformly tighten the bolts and nut in several passes.

Torque:

- 18.5 N-m (189 kgf-cm, 14 ft.-lbf) for A**
- 13 N-m (133 kgf-cm, 10 ft.-lbf) for B**
- 9 N-m (92 kgf-cm, 80 in.-lbf) for C**
- 11 N-m (113 kgf-cm, 8 ft.-lbf) for others**

NOTICE:

- Pay attention not to wrap the chain and slipper over the chain cover seal line.
- After installing the chain cover, install the mounting bracket and water pump within 15 minutes.

HINT:

Each bolt length in indicated in the illustration.

Bolt A	45 mm (1.77 in.) length 12 mm head
Bolt B	45 mm (1.77 in.) length 10 mm head
Bolt C	35 mm (1.38 in.) length 10 mm head
Bolt D	30 mm (1.18 in.) length 10 mm head
Bolt E	25 mm (0.98 in.) length 10 mm head

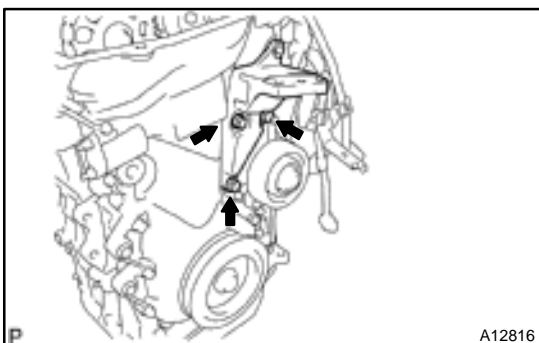

8. INSTALL RH ENGINE MOUNTING BRACKET

- (a) Apply seal packing to threads of the mounting bolt.
Seal packing: Part No. 08826-00080 or equivalent

NOTICE:

Do not apply seal packing to 2 or 3 threads of the bolt end.

- (b) Install the engine mounting bracket with the 3 bolts.
Torque: 47 N-m (479 kgf-cm, 35 ft.-lbf)

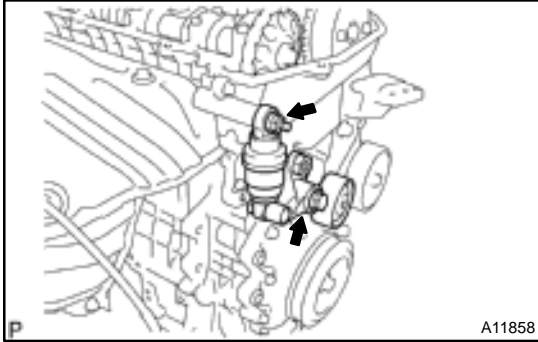

9. INSTALL DRIVE BELT TENSIONER

- (a) Install the drive belt tensioner with the bolt and nut.
Torque:
69 N·m (704 kgf·cm, 51 ft·lbf) for bolt
29 N·m (296 kgf·cm, 21 ft·lbf) for nut
- (b) Hook the tool on the hexagonal portion of the drive belt tensioner bracket and operate drive belt tensioner 3 times with full stroke.

HINT:

Take 3 seconds or more for 1 full stroke.

10. INSTALL CRANKSHAFT POSITION SENSOR

Torque: 9 N·m (92 kgf·cm, 80 in.-lbf)

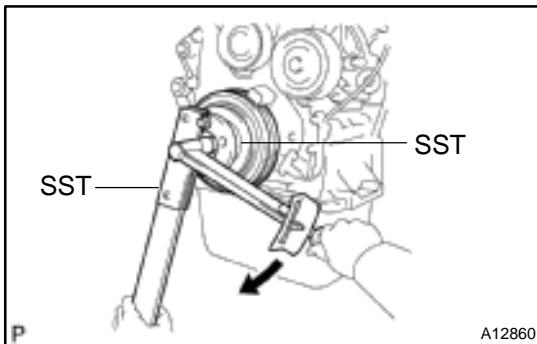

11. INSTALL CRANKSHAFT PULLEY

- (a) Clean the crankshaft pulley inside.
- (b) Align the pulley set key with the key groove of the pulley, and slide on the pulley.
- (c) Using SST, install the pulley bolt.
 SST 09213-70011, 09330-00021
Torque: 138 N·m (1,409 kgf·cm, 102 ft·lbf)

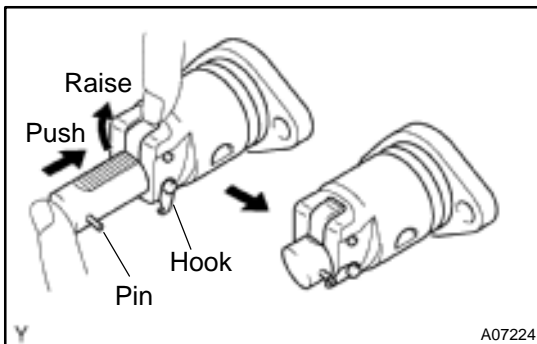

12. INSTALL CHAIN TENSIONER

- (a) Release the ratchet pawl, fully push in the plunger and apply the hook to the pin so that the plunger cannot spring out.
- (b) Install the O-ring to the chain tensioner.

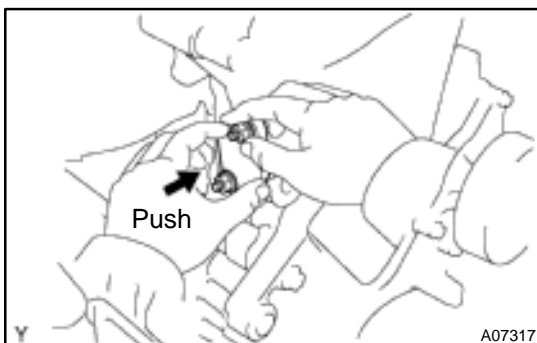

- (c) Push the chain tensioner into the timing chain cover, and install the 2 nuts.
Torque: 9 N·m (92 kgf·cm, 80 in.-lbf)

HINT:

- In case that the hook is released while pushing in, apply the hook again and push the tensioner in.
- Pay attention not to catch the O-ring as it is built in the chain tensioner previously.

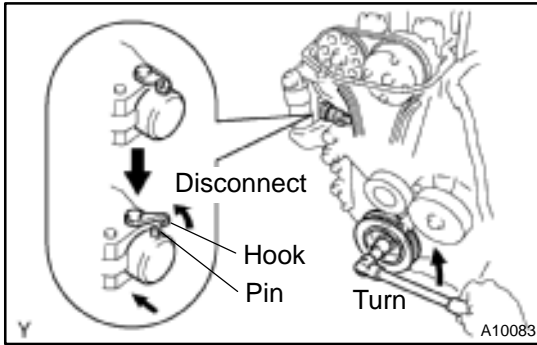
**13. SET CHAIN TENSION**

- (a) Turn the crankshaft counterclockwise, and disconnect the plunger knock pin from the hook.

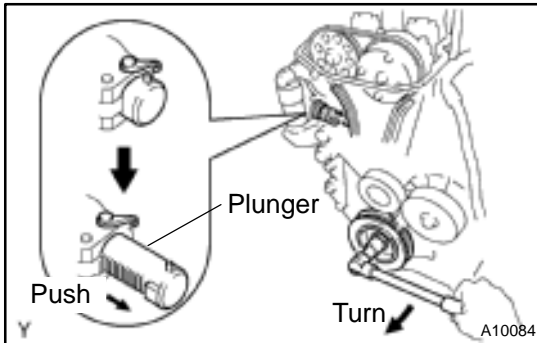

- (b) Turn the crankshaft clockwise, and check that the slipper is pushed by the plunger.

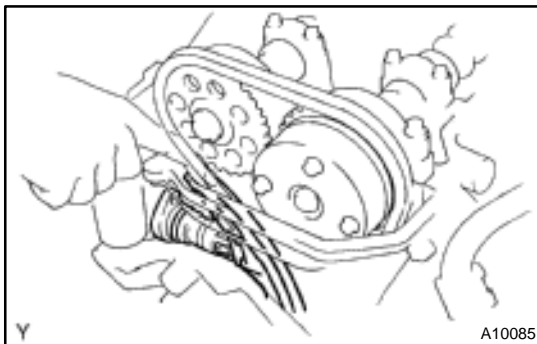
**HINT:**

If the plunger does not spring out, press the slipper into the chain tensioner with a screwdriver or your finger so that the hook is released from the knock pin and the plunger springs out.

14. CHECK VALVE TIMING

- (a) Turn the crankshaft pulley, and align its groove with timing mark 0 of the timing chain cover.

NOTICE:

Always turn the crankshaft clockwise.

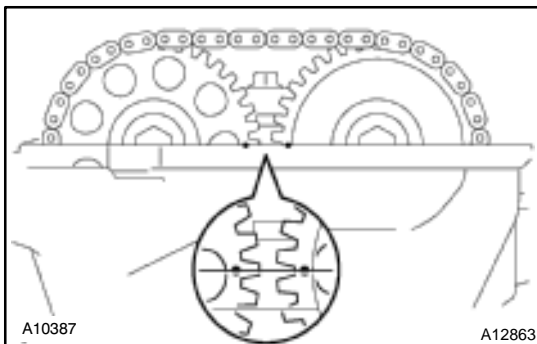

- (b) Check that the point marks of the camshaft timing sprocket and VVT timing sprocket are in straight line on the timing chain cover surface as shown in the illustration.

If not, turn the crankshaft 1 revolution (360°) and align the marks as above.

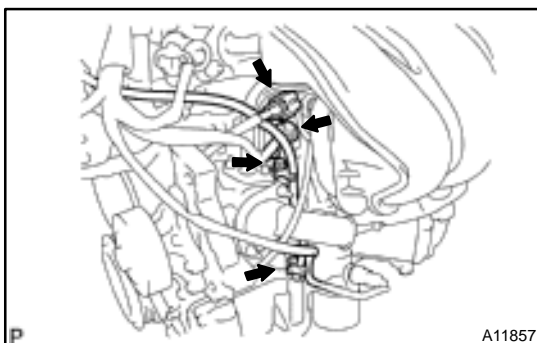
**15. INSTALL OIL DIPSTICK AND GUIDE**

- (a) Connect the knock sensor connector, crankshaft position sensor connector and oil pressure sensor wire bracket to the oil dipstick guide.

- (b) Install a new O-ring to the oil dipstick.

- (c) Install the oil dipstick and guide with the nut.

Torque: 13 N·m (133 kgf·cm, 10 ft·lbf)

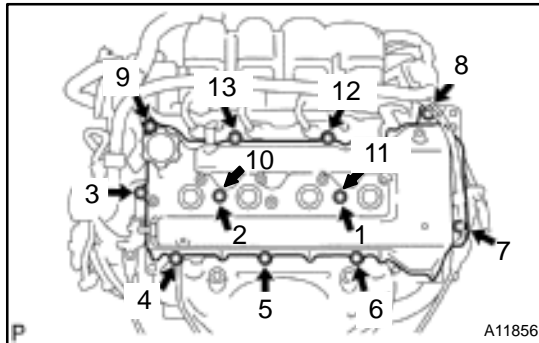
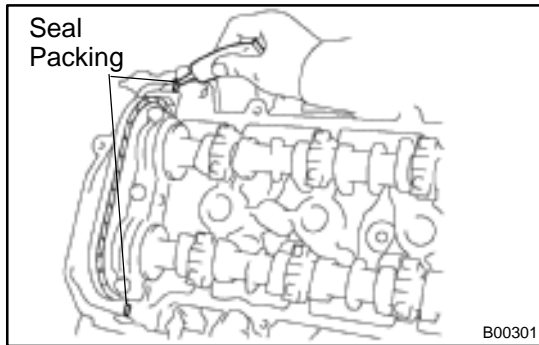

16. INSTALL CYLINDER HEAD COVER

- (a) Remove any old packing (FIPG) material.
- (b) Apply seal packing to 2 locations as shown in the illustration.

Seal packing: Part No. 08826-00080 or equivalent

- (c) Install the gasket to the cylinder head cover.

If the gasket has damage, replace a new one.

HINT:

Part must be assembled within 3 minutes of application. Otherwise the material must be removed and reapplied.

- (d) Install the cylinder head cover and engine wire bracket with the 9 bolts, 2 seal washers and 2 nuts. Uniformly tighten the bolts and nuts in the several passes, in the sequence shown.

Torque:

11 N·m (113 kgf·cm, 8 ft·lbf) for w/o washer

9 N·m (92 kgf·cm, 80 in·lbf) for w/ washer

- (e) Connect the noise filter.
- (f) Disconnect the heated oxygen sensor (bank 1 sensor 1) connector.
- (g) Connect the 2 PCV hoses to the cylinder head cover.

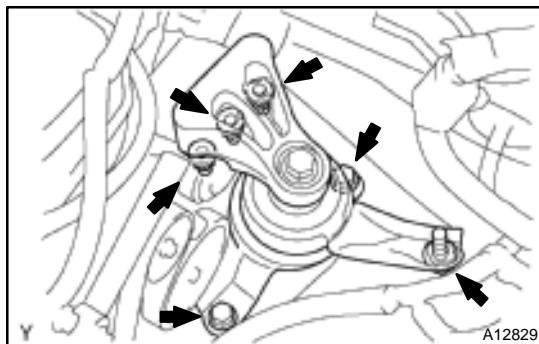

17. INSTALL RH ENGINE MOUNTING INSULATOR

- (a) Install the engine mounting insulator with the 3 bolts and 3 nuts.

Torque: 52 N·m (530 kgf·cm, 38 ft·lbf)

- (b) Remove the jack.

18. INSTALL IGNITION COILS (See page IG-4)

19. INSTALL NO. 2 CYLINDER HEAD COVER

Install the No. 2 cylinder head cover with the 2 nuts and 2 clips.

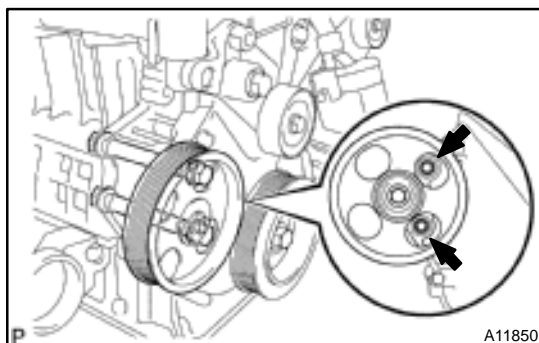

20. INSTALL DRIVE BELT IDLER

Torque: 36 N·m (370 kgf·cm, 27 ft·lbf)

21. INSTALL GENERATOR AND DRIVE BELT

(See page CH-17)

22. INSTALL ENGINE UNDER COVERS

23. INSTALL SUSPENSION UPPER BRACE

24. FILL WITH ENGINE COOLANT (See page CO-1)

25. START ENGINE AND CHECK FOR COOLANT LEAKS